

ATN is proud to introduce its new line of Image Intensifier tubes:

CGTI - CUSTOM GRADE TUBES



**AMERICAN
TECHNOLOGIES
NETWORK
CORP.**

1341 San Mateo Ave.,
South San Francisco,
CA 94080, USA
phone: 800-910-2862
650-989-5100
fax: 650-875-0129
www.atncorp.com

At ATN, we know that the performance and utility of a Night Vision Device (NVD) is directly due to its Image Intensifier Tube (IIT) performance. To meet the demands and expectations of our customers, we developed our new range of IITs.

Our Custom Grade Tubes (CGTI) are 'custom' because that is what they are: Custom! Engineered for significantly enhanced performance over current 2nd generation IITs, our CGTI tubes deliver the best performance to cost ratio in the marketplace. Units built with CGTI tubes allow agencies to outfit three people for the cost of two 3rd generation units, with similar results.

IIT performance grades are defined by two major parameters: Signal to Noise Ratio (SNR) and Resolution. New production technology has resulted in improved performance specifications.

Our CGTI Image Intensifier Tubes have a Signal-to-Noise ratio of 15 to 22, with a Resolution of 45-54lp/mm.

ATN's CGTI Tubes are fully compatible and interchangeable with ANVIS and PVS7 models available from competing manufacturers.

The ATN CGTI image intensifiers are available in two formats: Inverting and Non-inverting. They are 18mm NT's designed in a compact and Drop in format. They consist of a Multi-Alkaline photocathode, microchannel plate, built-in power supply and flat glass input window.

The **I160 Series** are fully compatible and interchangeable for use in all night vision systems that use an inverting tube such as AN/PVS-6, 9, 6015 models, MUM-14 mini-monocular, NVM-14 and various commercial models available from competing manufacturers.

The **N130 Series** image intensifier tubes (IITs) are fully compatible and interchangeable for use in all night vision systems that use a non-inverting tube such as AN/PVS-7, NVG-7, PS22 and various commercial models available from competing manufacturers.

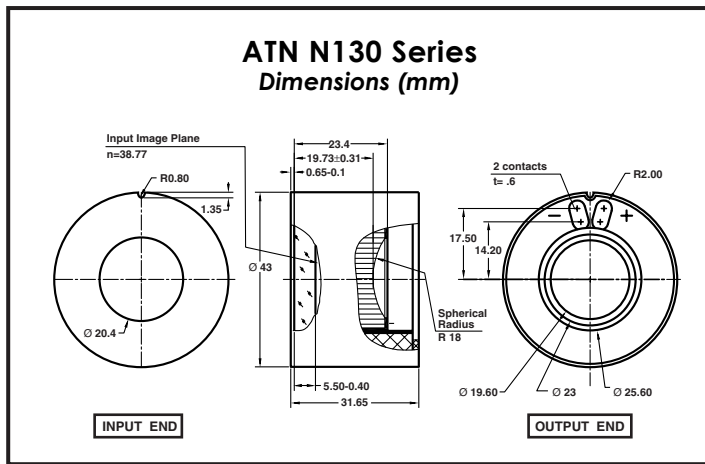

I160 IITs are compatible with AN/PVS - 6, 9, 6015, MUM-14, NVM-14 and numerous commercial models.

N130 IITs are compatible with AN/PVS - 7, NVG-7 and numerous commercial models.

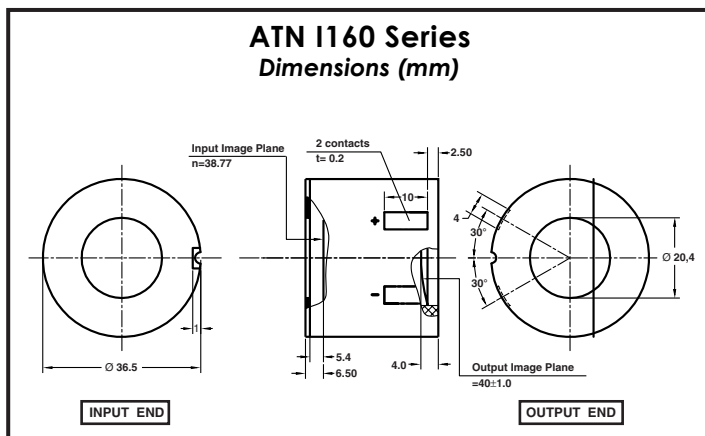

MAIN PARAMETERS:		
SPECIFICATION	N130-CGTI	I160-CGTI
Photocathode Diameter, mm	18	18
Photocathode Type	S-25	S-25
Resolution, lp/mm	45-54	45-54
Signal to Noise ratio	15 to 22	15 to 22
FOM	less then 1250	less then 1250
Image magnification	1x	1x
Current consumption, max, mA	16	16
Voltage, V	2,8 ± 0,8	2,8 ± 0,8
Weight, g	90	90
Shock resistance, g	500	500
Mean time before failure, hours	10,000	10,000
MODULAR TRANSFER FUNCTION		
	2.5	
	7.5	
	15	

MAXIMUM SPOTS ALLOWED IN FIELD OF VIEW:					
Zone Number	Circular zone Dimensions, mm	Maximum diameter of spots			Admitted total Area of defects, mm ²
		Neglected	Admitted		
			Diameter, mm	Quantity	
1	0 - 9,0	0.1	0.15	1	0.15
2	9,0 - 14,5	0.12	0.25	2	0.3
3	14,5 - 18	0.15	0.35	2	0.5

Export of night vision equipment is controlled by the U.S. Department of State, Office of Defense Trade Controls in accordance with International Traffic in Arms (ITAR), Title 22, Code of Federal Regulations Part 120-130 and/or the Export Administration Regulations (EAR) U.S. Department of Commerce. Illegal export of these commodities is strictly prohibited.

American Technologies Network, Corp.

1341 San Mateo Ave., South San Francisco, CA 94080 USA
 phone: 800-910-2862, 650-989-5100; fax: 650-875-0129, www.atncorp.com

